

KURTOSYS

**Visual
brand
guidelines.**

Contents

This document will help you understand the elements and rules to our identity system. Use this as a source of truth and inspiration to help successfully apply the Kurtosys brand.

1. Introduction

1.1	TONE OF VOICE	03
1.2	DESIGN PRINCIPLES	04
1.3	BRAND PERSONALITY	05

2. Logomark

2.1	KURTOSYS LOGO + PLACEMENT	06
2.2	KURTOSYS DOUGHNUT	07
2.3	PARTNERSHIP LOCKUP	08

3. Typography

3.1	TYPEFACE	09
3.2	HIERARCHY OF ELEMENTS	10
3.3	TITLES + SIZE GUIDES	11

4. Colour

4.1	BRAND COLOUR PROFILES	12
4.1	COLOUR APPLICATION	13
4.2	BACKGROUND COLOURS	14

5. Icons

5.1	GENERAL ICONS	15
5.2	KURTOSYS APP ICONS	16

6. Expressions

6.1	EXPRESSIONS	17 - 18
6.2	NOTES	19
6.3	ANNOTATIONS	20 - 21

7. Web + UI elements

7.1	BUTTONS	22
7.2	FORM ELEMENTS & LAYOUT	23
7.3	INPUTS	24

8. Social media

8.1	POST TYPES	25
8.2	POST COMPOSITIONS	26

9. Email signature

9.1	STANDARD EMAIL SIGNATURE	27
-----	--------------------------	----

10. White paper

10.1	WHITE PAPER LAYOUT	28 - 29
------	--------------------	---------

11. Presentations

11.1	POWERPOINT TEMPLATE	30
------	---------------------	----

Introduction

Tone of voice.

Use these quick, simple tips as a guide to steer our communication approach.

Sentence case.

Keep it conversational. [!]

We use first person plural.

Keep numerals consistent.

Align with our terminology.

Use exclamations sparingly.

Use gender neutral language.

~~No corporate/technical jargon.~~

Show emotion with expressions. ✧

Introduction

Hello, we're Kurtosys

Digital + reporting solutions for investment managers.

We're a secure cloud-based platform that seamlessly puts investment data & insights at your clients' fingertips.

Design principles.

1.

Simplicity is key

We have a clear identity at all times, even when it's used to communicate complex processes and features.

2.

High contrast

We always ensure full accessibility, utilising strong colour schemes defined from our unique brand palette.

3.

The perfect balance

We believe all information should be digestible and flow seamlessly. Avoid overload, lead with clarity.

Introduction

Brand personality.

We're the Reliable Revolutionist, unafraid to challenge the status quo.

We look into the past only to take expert knowledge into the future. We bravely guide people into exciting new worlds of finance, combining years of intelligence with bold imagination to constantly evolve investment insight and data.

To keep us moving. Together.

Innovative
Responsive
Approachable
Confident
Effective

Reliable
Partners
Professional
Authoritative
People

Human
Genuine
Engaging
Exciting
No-bullsh*t

Logomark

Primary logo

KURTOSYS

The Kurtosys logotype consist of a wordmark in combination with the circular graphic, making the letter O in kurtosys.

Blue is the primary colour for the logo and we use the white version so that it can be placed on dark backgrounds.

Always ensure that there is enough space around the logo. No other visual or text element should encroach this space.



Stacked logo with byline



Horizontal logo with byline

The horizontal logo with byline should be used when the available area is wider than it is high.



Doughnut

The donut is our icon symbol and consists of the \odot from our Kurtosys logo. It is used only in certain applications, especially online and social media avatars.

The doughnut is not a substitute for our Kurtosys logo, but rather a complimentary icon or symbol that references the logo. It should never be used in isolation.

KURTOSYS

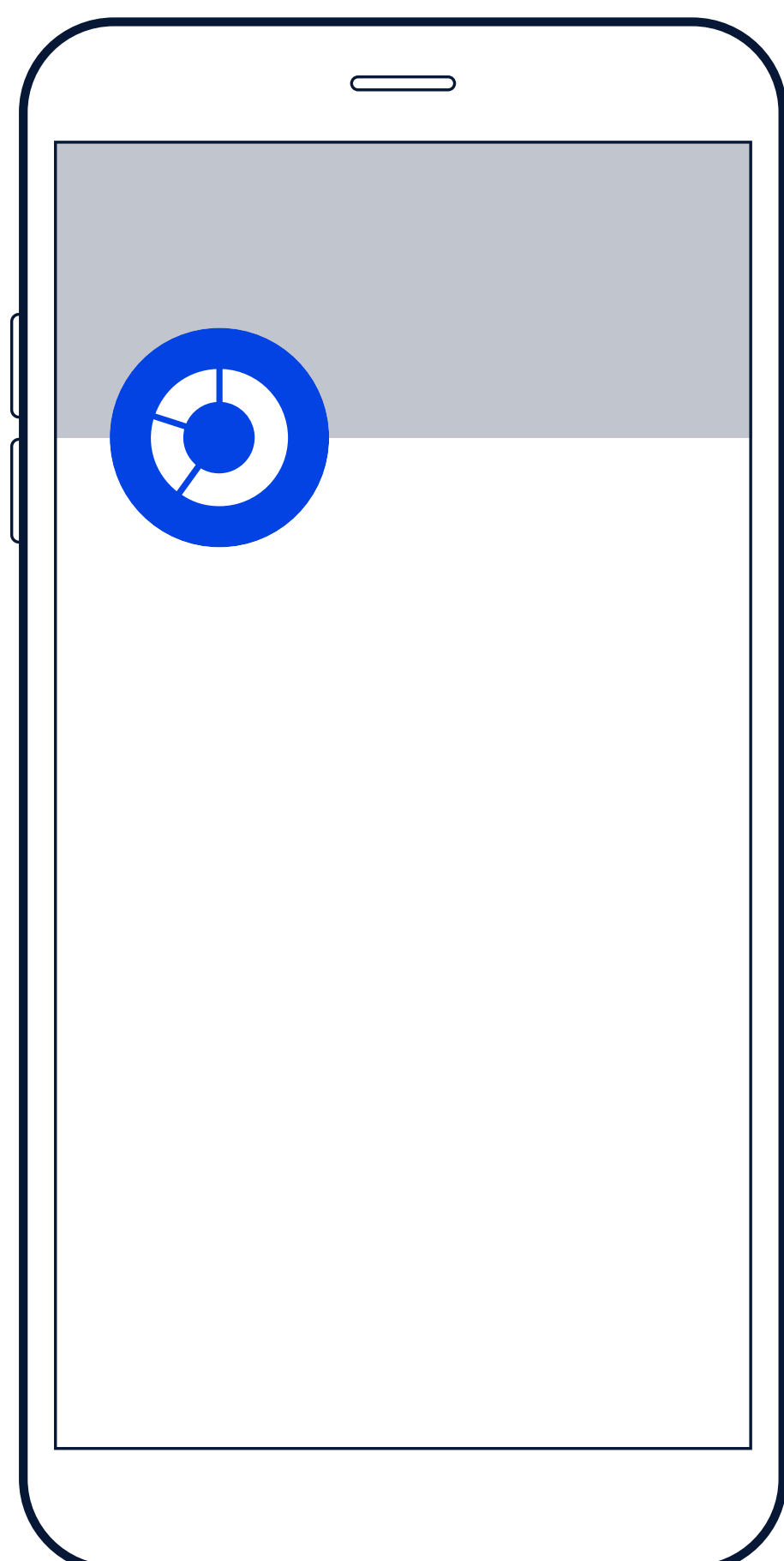
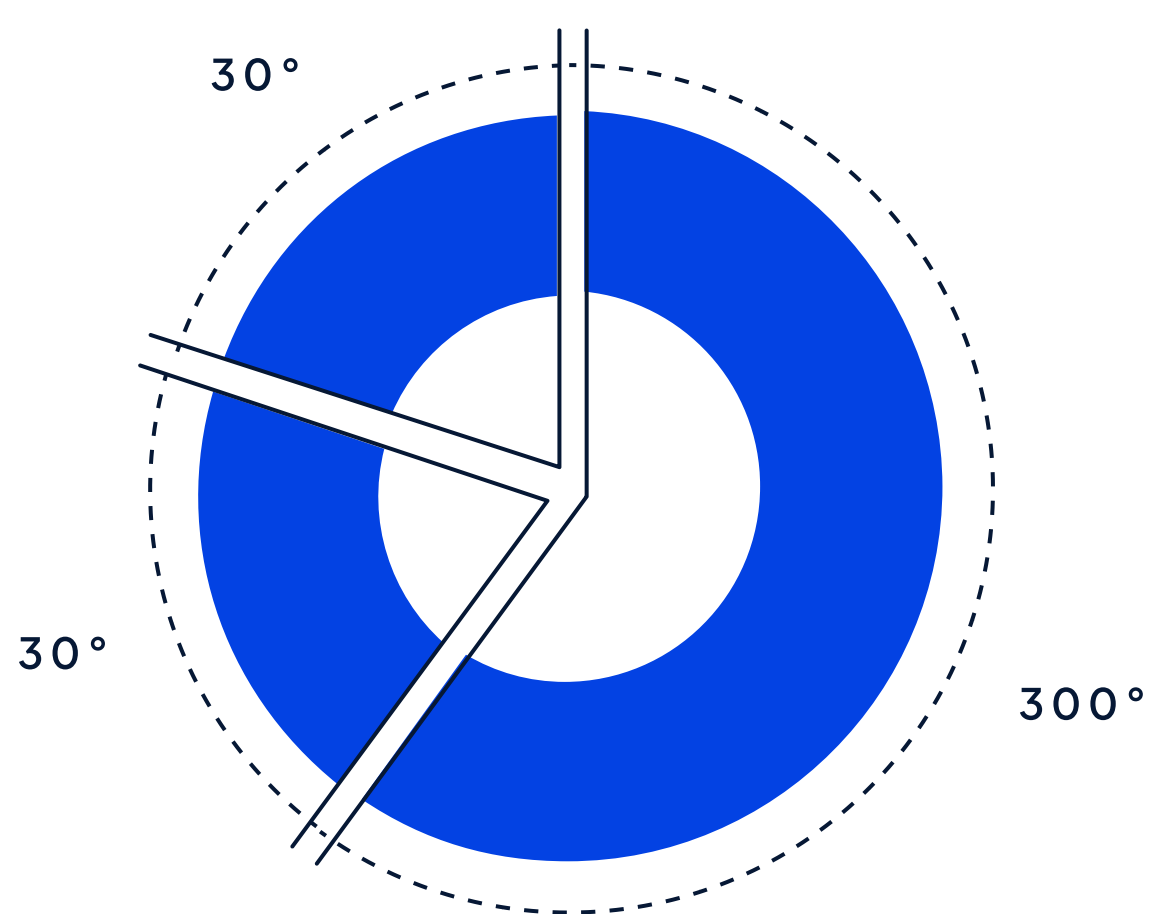
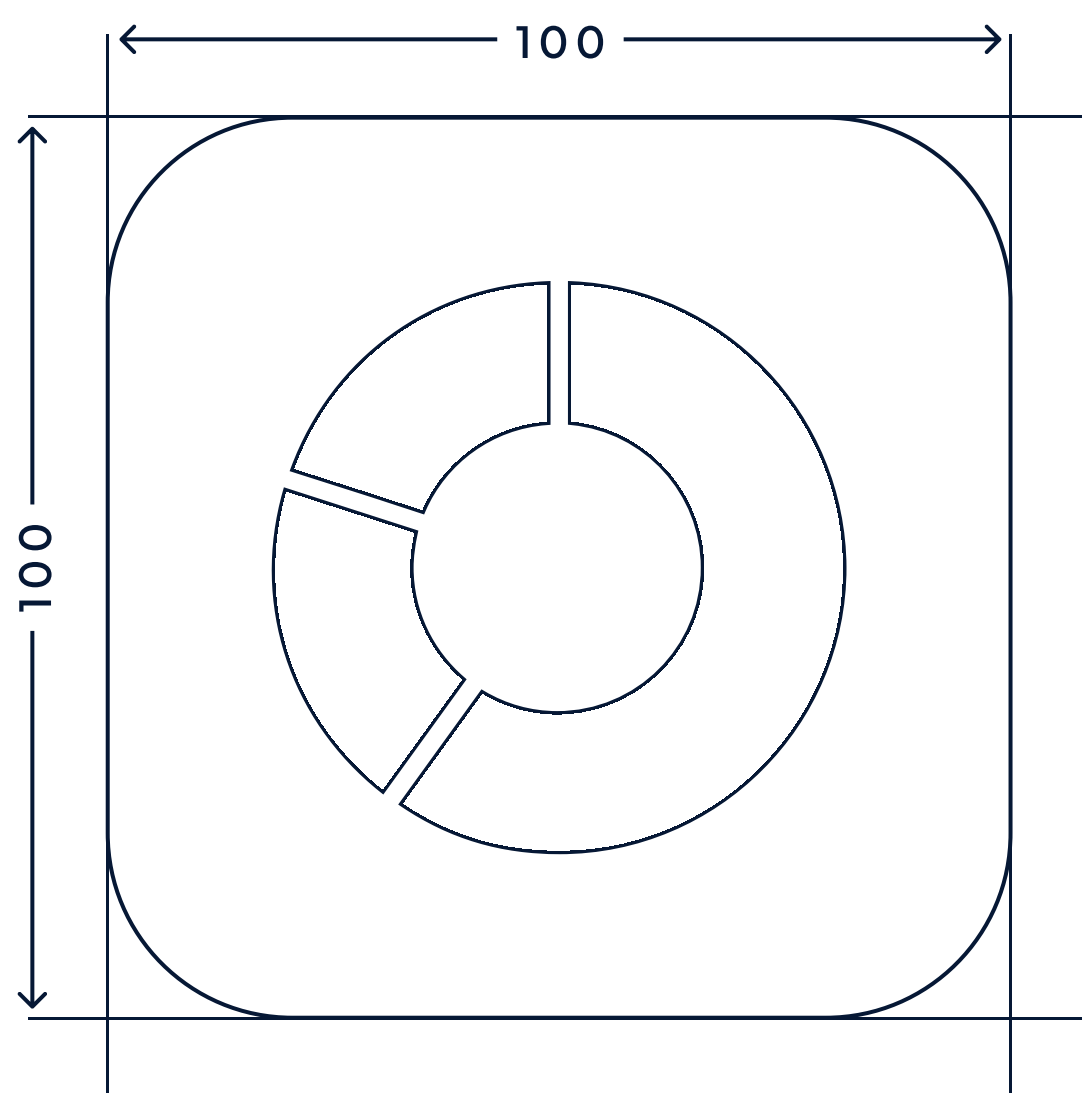

Relationship lockup

PARTNER LOGO

PRIMARY KURTOSYS LOGO

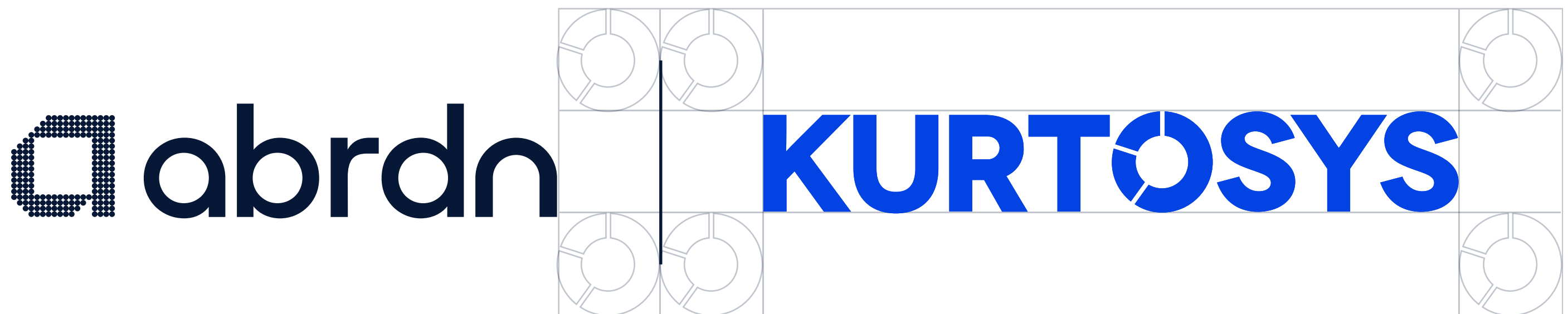

The relationship logo lockup is primarily horizontal oriented, with the logo left-aligned and a thin line separating it from the primary Kurtosys logo on the right.

PARTNER LOGO

PRIMARY KURTOSYS LOGO

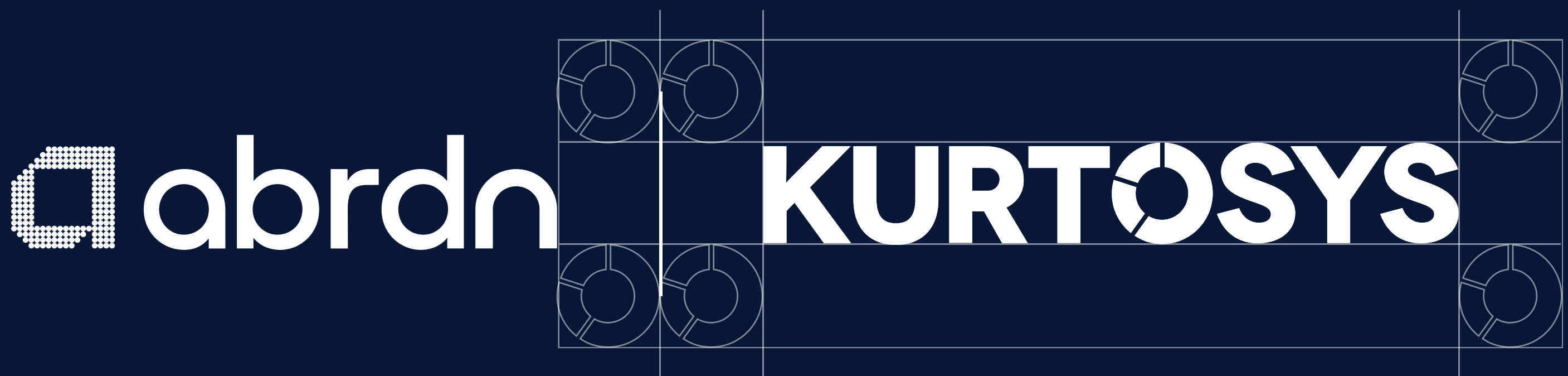

Should the partner logo appear on a solid, darker background, the inverted version of both logos should be employed.

Typography

Typography is a
fundamental pillar
in our identity.

Overview

Kurtosys' typography is designed and tested in conjunction with our colour palette. Ensuring a bold, accessible experience, fundamental to our identity.

Kurtosys'
typography is
dynamic, high
contrast and
legible.

Typeface

Kurtosys' typography is designed and tested in conjunction with our colour palette. Ensuring a bold, accessible experience, fundamental to our identity.

LIGHT	300	Plus Jakarta Sans
REGULAR	400	Plus Jakarta Sans
MEDIUM	500	Plus Jakarta Sans
SEMI-BOLD	600	Plus Jakarta Sans
BOLD	700	Plus Jakarta Sans

Plus Jakarta Sans.

Hierarchy of elements

Eyelid or **pre-header** text is typically used to denote a topic or chapter, or describe content to follow. It may not always be required.

A **mega paragraph** refers to enlarged text used to highlight a quote or a piece of essential information. Its application is both creative and utilitarian.

Body type refers to standard type - the written content in the body of the document.

A **section title** is large text that describes the following section or chapter in only a few words. It is used once at the start of each new section.

Paragraph header text is used at the start of a paragraph/(s) as a header or short summary of content in the paragraph to follow.

Small body type is used in sections that are less important and is typically used for non-essential information or in the lower footer area.

Eyelid / pre-header

Section title

Mega paragraph

Paragraph header

Body

Small body

YOU MIGHT LIKE TO KNOW

We love what we do

Our platform integrates seamless API connectivity, advanced analytics, and secure cloud-based infrastructure to enable real-time insights.

Driving innovation with scalable fintech solutions

Empowering businesses through cutting-edge financial technology, we streamline digital transformation with scalable solutions that optimize operational efficiency and enhance data-driven decision-making.

*We promise to keep your data safe, but if the robots ever take over, we might have to renegotiate.

Titles

	Size	Line-height	Weight
Huge title	140PX 8.75EM	176	700
Extra large title	100PX 6.25EM	126	700
Very large title	82PX 5.125EM	103	600
Large title	72PX 4.5EM	91	600
Medium title	60PX 3.75EM	76	600
Regular title	46PX 2.875EM	42	600

Headings

	H1	H2	H3	H4	H5	H6
Size	40PX 2.5EM	34PX 2.125EM	28PX 1.75EM	24PX 1.5EM	18PX 1.25EM	16PX 1EM
Line-height	50	43	35	30	23	20
Weight	700	700	700	700	700	700

	Body Large	Body regular	Body small	PRE-HEADER / PARAGRAPH EYELID
Size	18PX 1.25EM	16PX 1EM	14PX 0.875EM	12PX 0.75EM
Line-height	28	24	18	16
Weight	500	400	400	500

Primary colour palette

Triple A (AAA) is the gold standard level of accessibility, which provides everything for a complete accessible compliance.

Primary colours

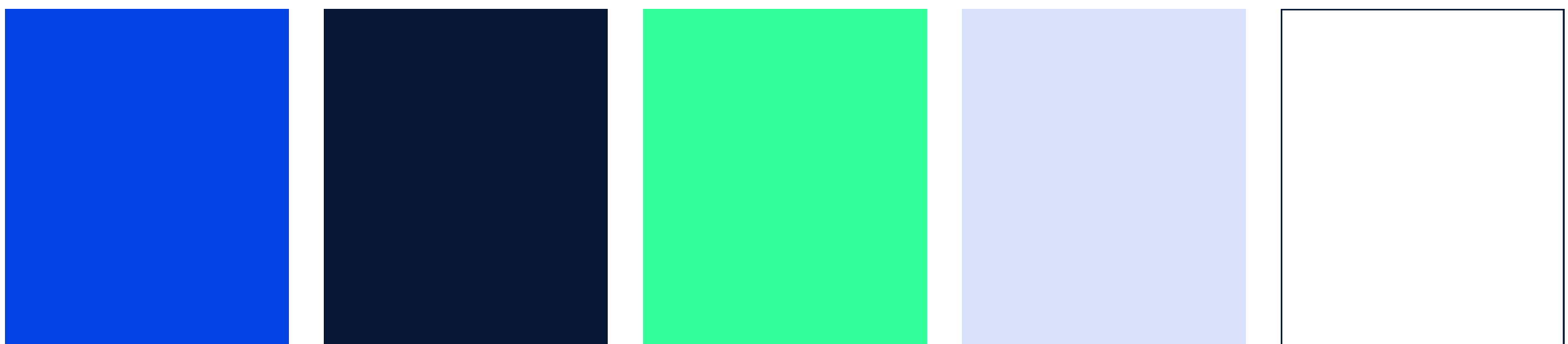

	Kurtosys Blue	Night Blue	Highlight Green	Cloud Blue	Crisp White
HEX	#0342E4	#071935	#31FF9C	#D9E3FB	#FFFFFF
RGB	3 66 28	7 25 52	49 255 156	217 277 251	255 255 255
CMYK	88 64 0 11	18 11 0 79	81 0 39 0	13 9 0 2	0 0 0 0
PANTONE	2728 C	282 C	7479 C	656 C	

Secondary colours



The secondary palette is used only to provide alternate background colours for client, resources and company specific content. They are exclusive to these areas.

	Client Green	Resource purple	Company Maroon
HEX	#31FF9C	#210735	#350723
RGB	49 255 156	3 7 53	53 7 35
CMYK	81 0 39 0	8 18 0 79	8 18 0 79
PANTONE	627 C	2695 C	7449 C

Triple A (AAA) is the gold standard level of accessibility, which provides everything for a complete accessible compliance.

Aa

ABCDEFGHIJKLMNOPQRSTUVWXYZ
 abcdefghijklmnopqrstuvwxyz
 1234567890!@#%&'()*+,-./:;<=>?[]^_`{|}~

Plus Jakarta Sans

Semi-bold

Ff

ABCDEFGHIJKLMNOPQRSTUVWXYZ
 abcdefghijklmnopqrstuvwxyz
 1234567890!@#%&'()*+,-./:;<=>?[]^_`{|}~

Plus Jakarta Sans

Regular

Xx

ABCDEFGHIJKLMNOPQRSTUVWXYZ
 abcdefghijklmnopqrstuvwxyz
 1234567890!@#%&'()*+,-./:;<=>?[]^_`{|}~

Plus Jakarta Sans

Regular

Primary colours

Night blue

HEX 00FFBB
 RGB 22 34 128
 CMYK 22 89 19 33

Kurtosys blue

HEX 00FFBB
 RGB 22 34 128
 CMYK 22 89 19 33

Highlight green

HEX 00FFBB
 RGB 22 34 128
 CMYK 22 89 19 33

Cloud blue

HEX 00FFBB
 RGB 22 34 128
 CMYK 22 89 19 33

Crisp white

HEX 00FFBB
 RGB 22 34 128
 CMYK 22 89 19 33

Secondary colours

Company maroon

HEX 00FFBB
 RGB 22 34 128
 CMYK 22 89 19 33

Resource purple

HEX 00FFBB
 RGB 22 34 128
 CMYK 22 89 19 33

Client green

HEX 00FFBB
 RGB 22 34 128
 CMYK 22 89 19 33

The secondary palette is used only to provide alternate background colours for client, resources and company specific content. They are exclusive to these areas.

Background colours

Text + backgrounds

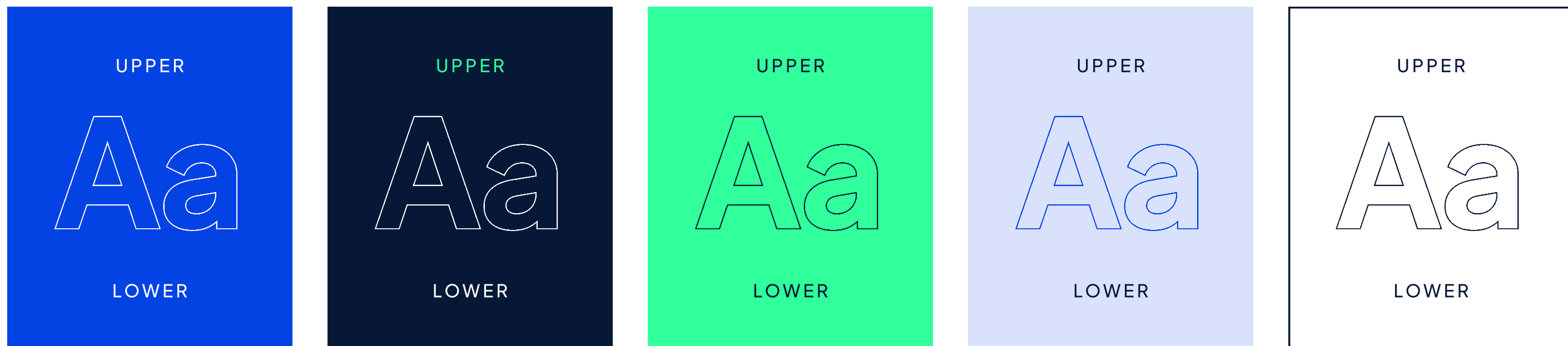

Logo + backgrounds

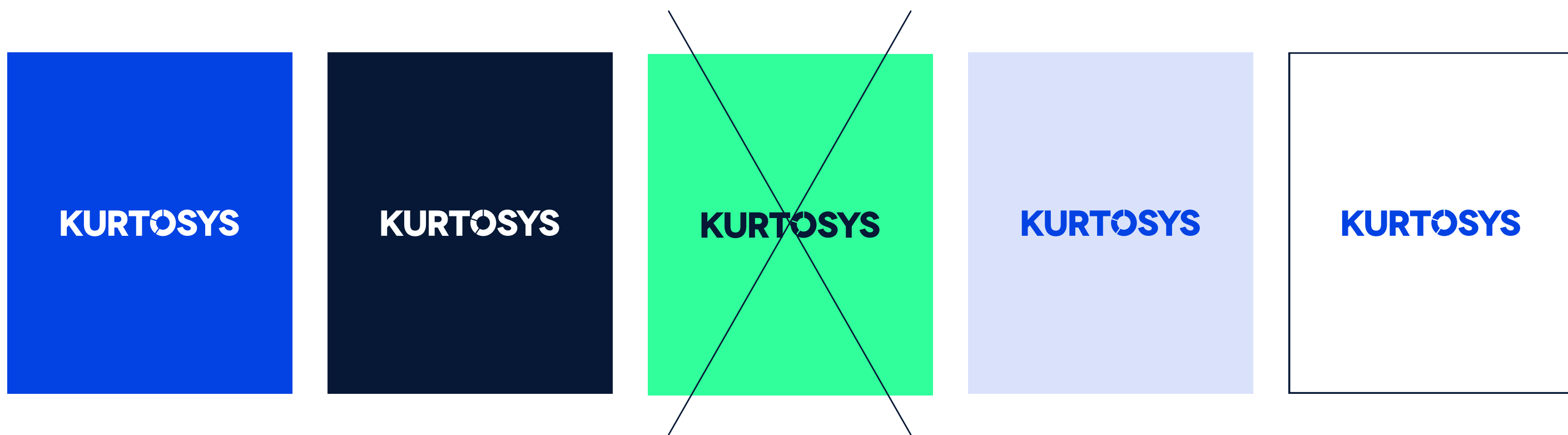

Buttons + backgrounds

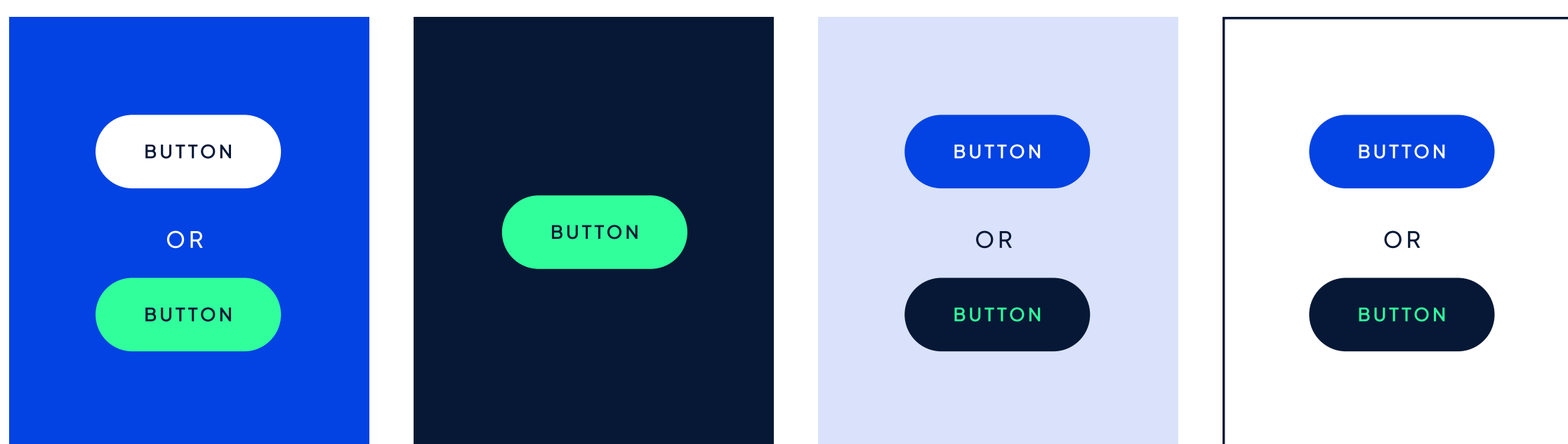

Icons / other scalable graphics

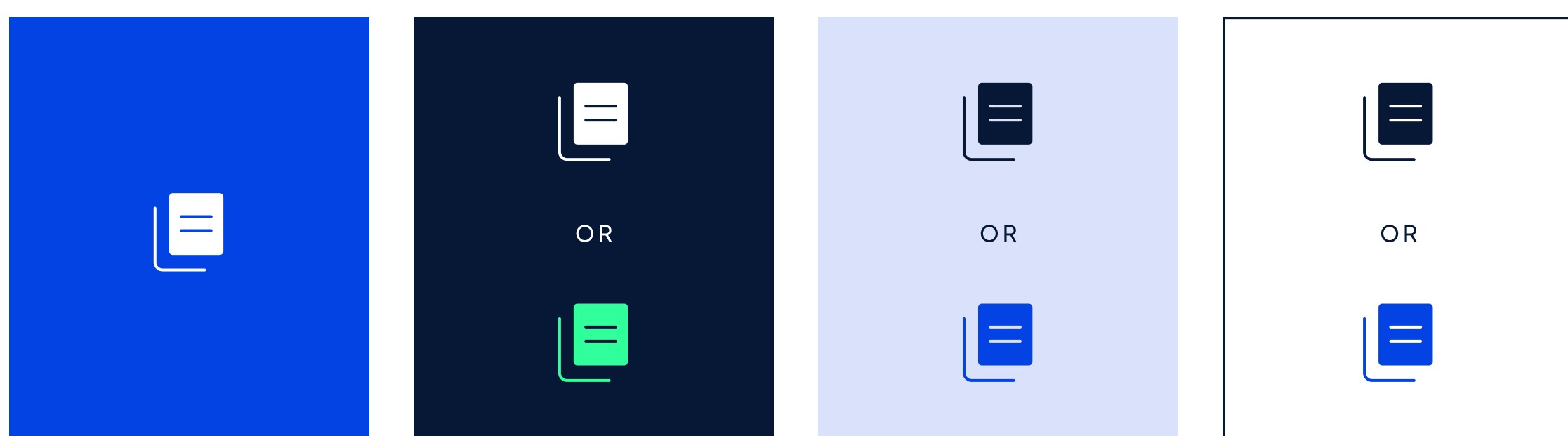

Icons

Arrows



Symbols



Media

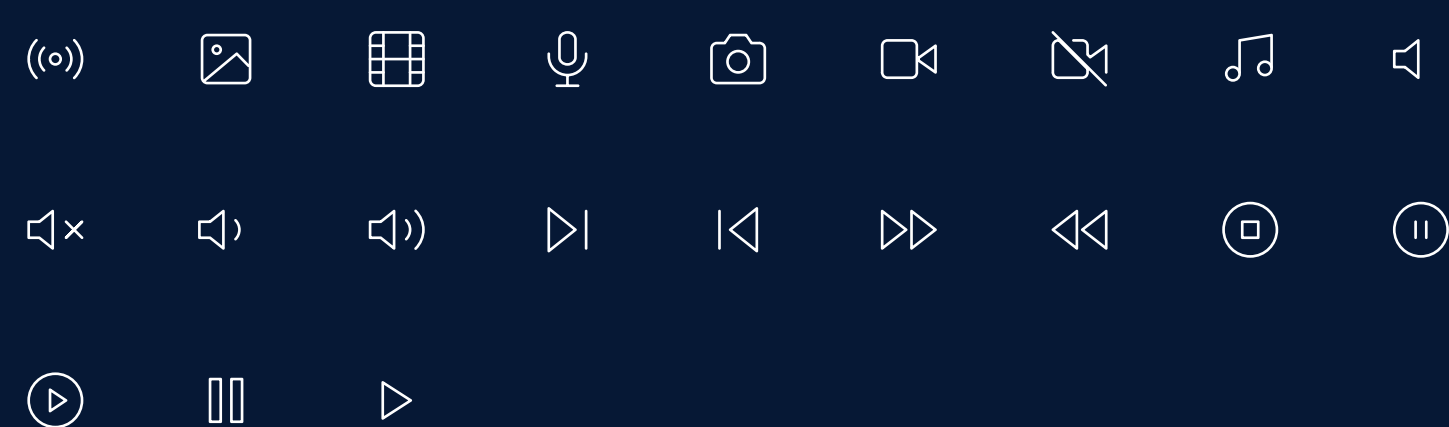

Interface



Files

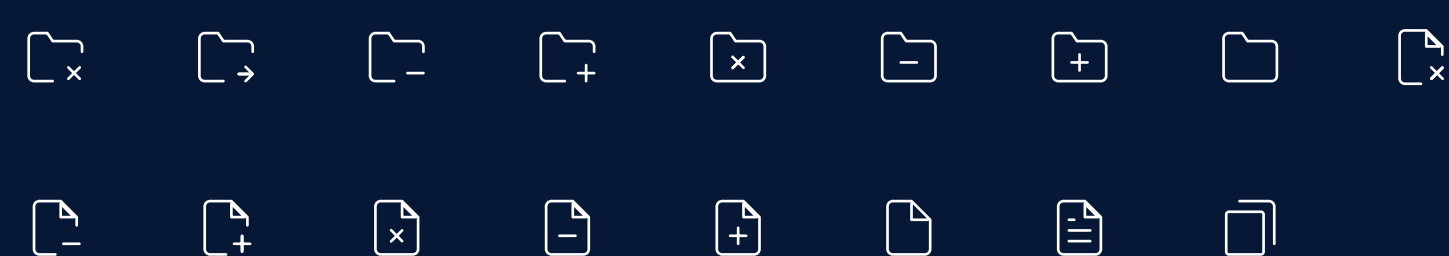

Editor

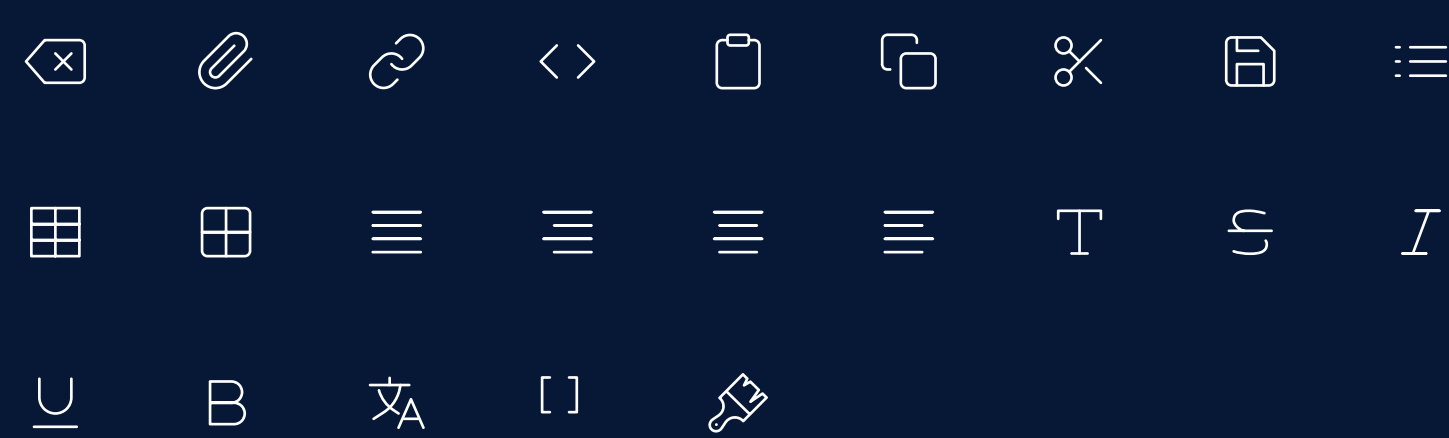

Layout



Devices



Users



Charts



Kurtosys app icons

The Kurtosys app icon collection is used strictly for product consists of 6 unique line and solid icons.

LINE

SOLID

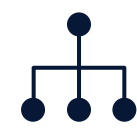
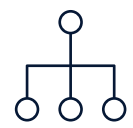
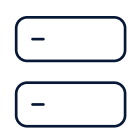
**Kurtosys DXM****Kurtosys Documents****Kurtosys Data****Kurtosys Studio****Kurtosys Communities****Kurtosys PaaS**

Expressions

The expression library consists of unique hand-drawn strokes forming highlights, underlines, strikethroughs and arrows. Expressions can be stretched and distorted, but the stroke width must remain 3pt.



Expressions

We use expressions to complement complex information, providing a guiding brand voice that understands the user.

EXPRESSION: UNDERLINE

Getting down to results.

EXPRESSION: STRIKETHROUGH

~~Pain~~-free investment.

EXPRESSION: HIGHLIGHT

Deliver faster.

EXPRESSION: SHINE

We are here to empower you and your organisation.

EXPRESSION: BESPOKE

From this  to this.

Notes

We use Notes to complement complex information, providing a guiding brand voice that understands the user.

Introducing Notes.

We apply Notes in two ways

EXPRESSING



Expressions are lines used to guide and highlight key information for the user.

ANNOTATING



Handwritten details to support and give further insight to headline copy.

Notes follow three simple application rules

Don't overdo it, please.

Use Notes sparingly - less is more.

Only when it adds value.

Use Notes to complement headline text.

Keep it Green.
Keep it 3pt.

Create Notes in Highlight Green, using a 3pt stroke width.

Annotations

Annotations can be used alongside expressions or on their own to complement headline text.

Annotations should only be limited to five – six words maximum.

Keep it short and concise.

Notes and expressions should always be used sparingly.

Create notes using highlight green and a 3pt stroke width.

Investment data & insight delivery.

(the pain-free way)

A secondary layer to core typography that allows us to inject our brand personality.

*-with a
human touch*

Annotations

Step 1: Visit [Caligrapher.ai](https://caligrapher.ai)

Adjust the settings to: **Speed: Max / Legibility: Max / Stroke width: 70% / Style: 7**. We exclusively only use these settings. Type a short message in lowercase and select **Write**. (Selecting Write again will generate a slightly different variation.)

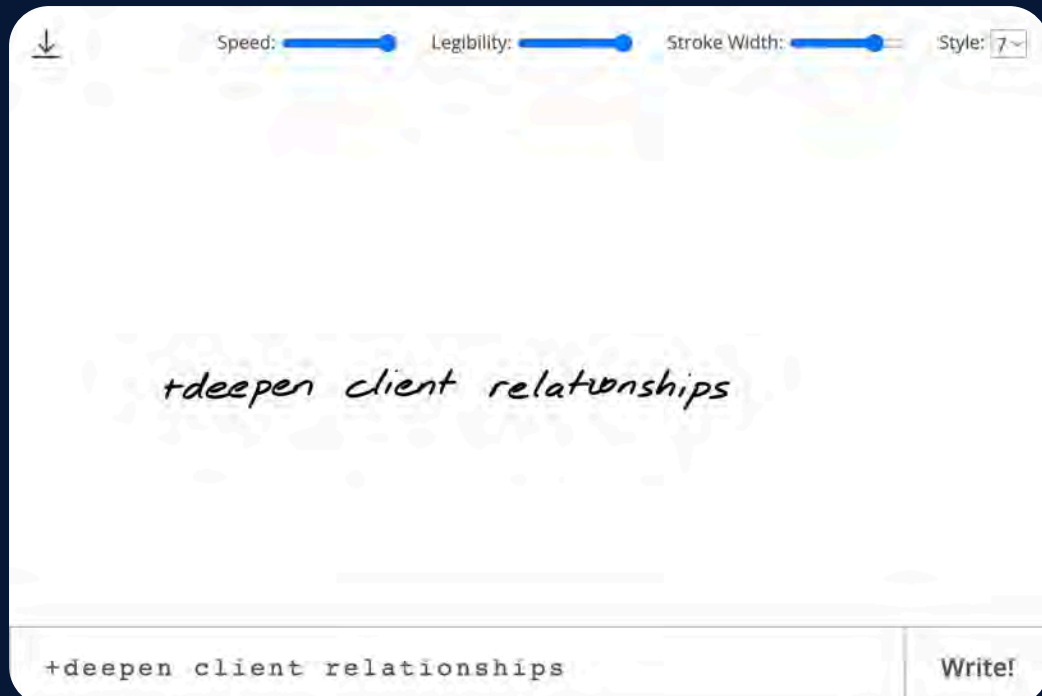

Step 2: Download

Click the icon in the top left corner to download an SVG of your text.



Step 3: Import

Import your SVG, in this example we're using Figma, so we can drag the file into the application. The SVG is black by default, let's change this to Highlight Green.

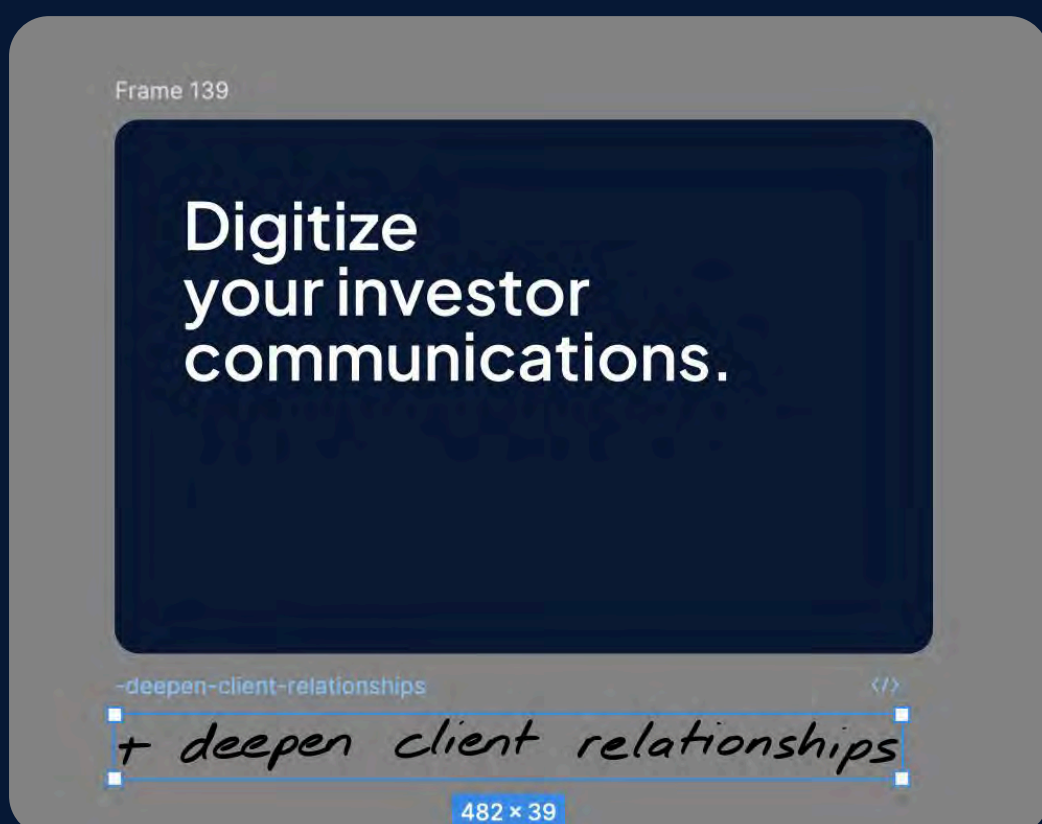

Step 4: Resize

Resize height of the SVG to the x-height of the headline (as shown within the red lines). As a principle, this is the maximum size the SVG can be against the headline.

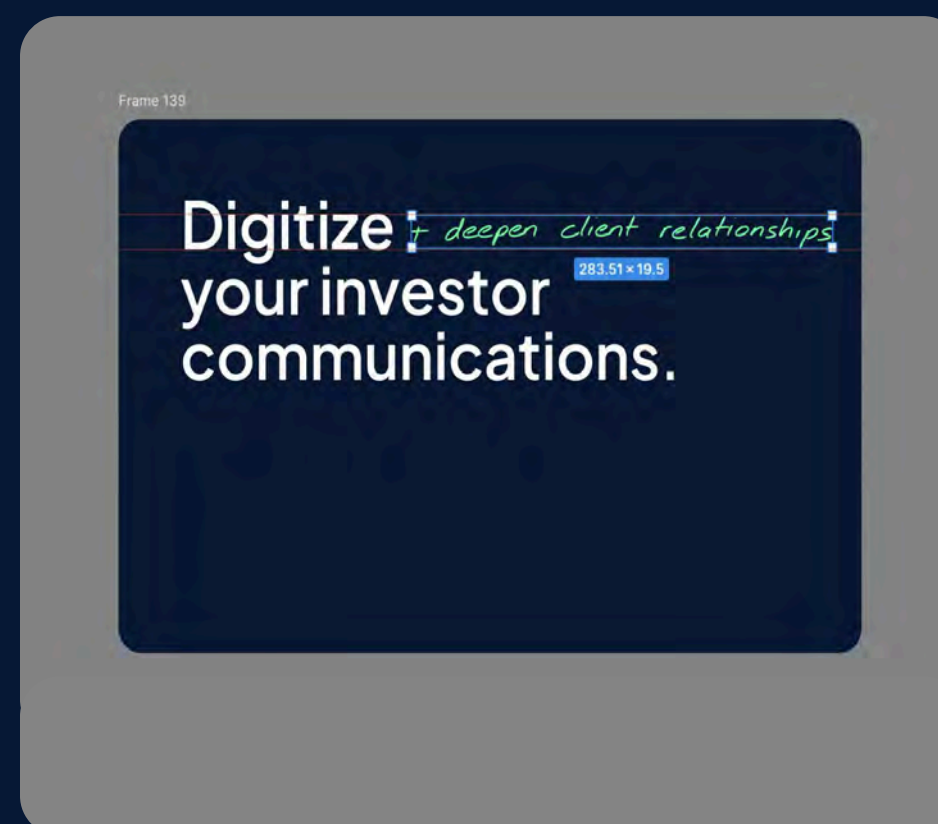

Step 5: Reposition

Reposition the SVG underneath the headline. Consider the best position for readability and space working with the headline.



Optional tweaks

Try these optional tweaks for further enhancement:

- Angle the SVG by $\pm 2^\circ$
- Manually tightening the words together

Buttons

Buttons should only be used on digital web pages where they can be interacted with, and not as decorative elements in presentations or print media. Buttons should be used sparingly, at the end of a section. They may be placed next to each other or stacked vertically, if required.

States + colour

DEFAULT

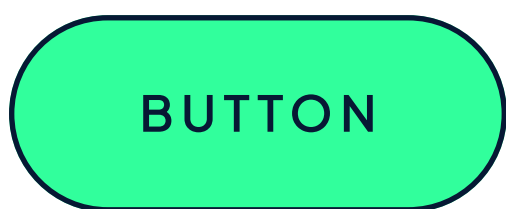
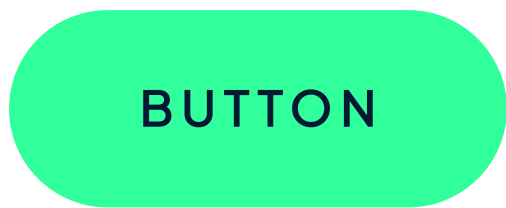
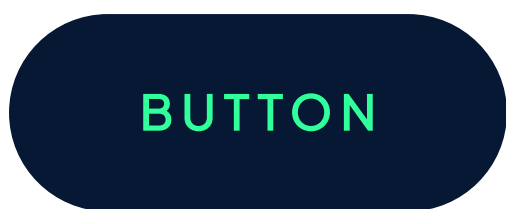

HOVER / ACTIVE

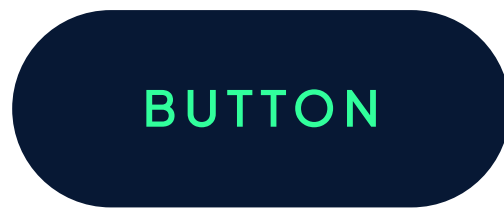
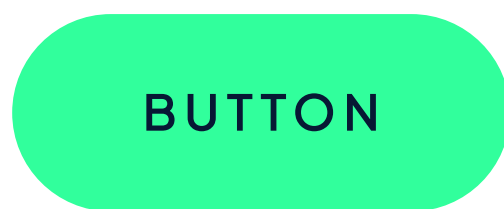

Types

PRIMARY

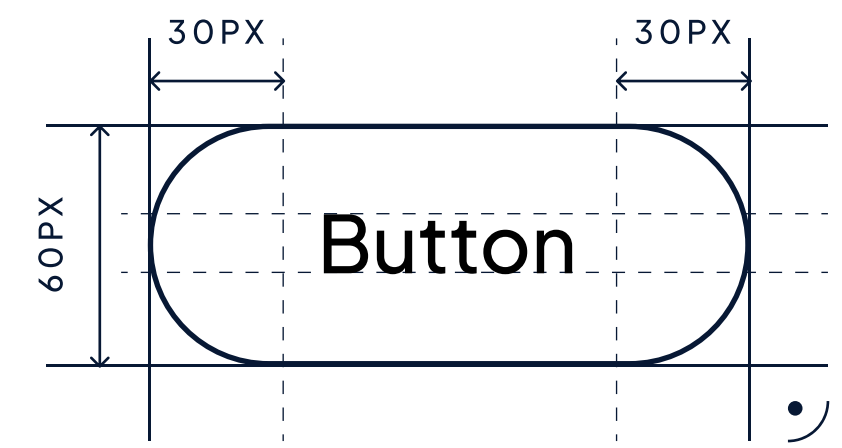

FONT SIZE:
TEXT-TRANSFORM:
WEIGHT:
LETTER-SPACING:
LINE-HEIGHT:

16PX / 1EM
SENTENCE CASE
SEMI-BOLD
0%
AUTO

SECONDARY

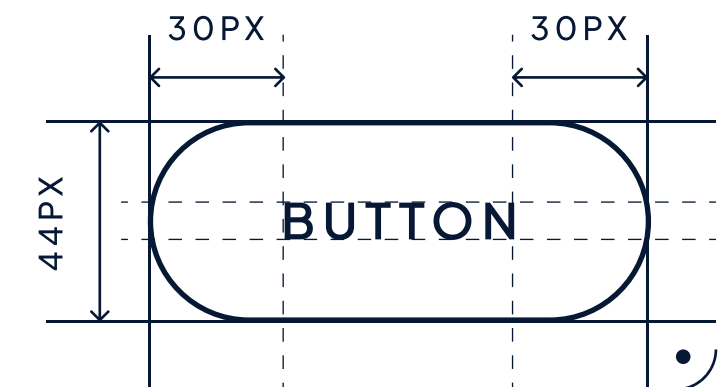

FONT SIZE:
TEXT-TRANSFORM:
WEIGHT:
LETTER-SPACING:
LINE-HEIGHT:

11PX / 0.6875EM
UPPERCASE
SEMI-BOLD
15%
AUTO

BUTTON + ICON



Forms

Styles

The text within a field or button should always appear vertically centered. Buttons are available in a variety of styles (refer to Buttons section) which can be employed in forms. Button font style does not necessarily need to match the style of text used in the field placeholder, typed text or label.

With horizontal forms, the button width is dynamic as it's a combination of the left and right padding, and the button text, which will vary. When form fields and input elements are stacked however, the fields and button should always be equal in width.

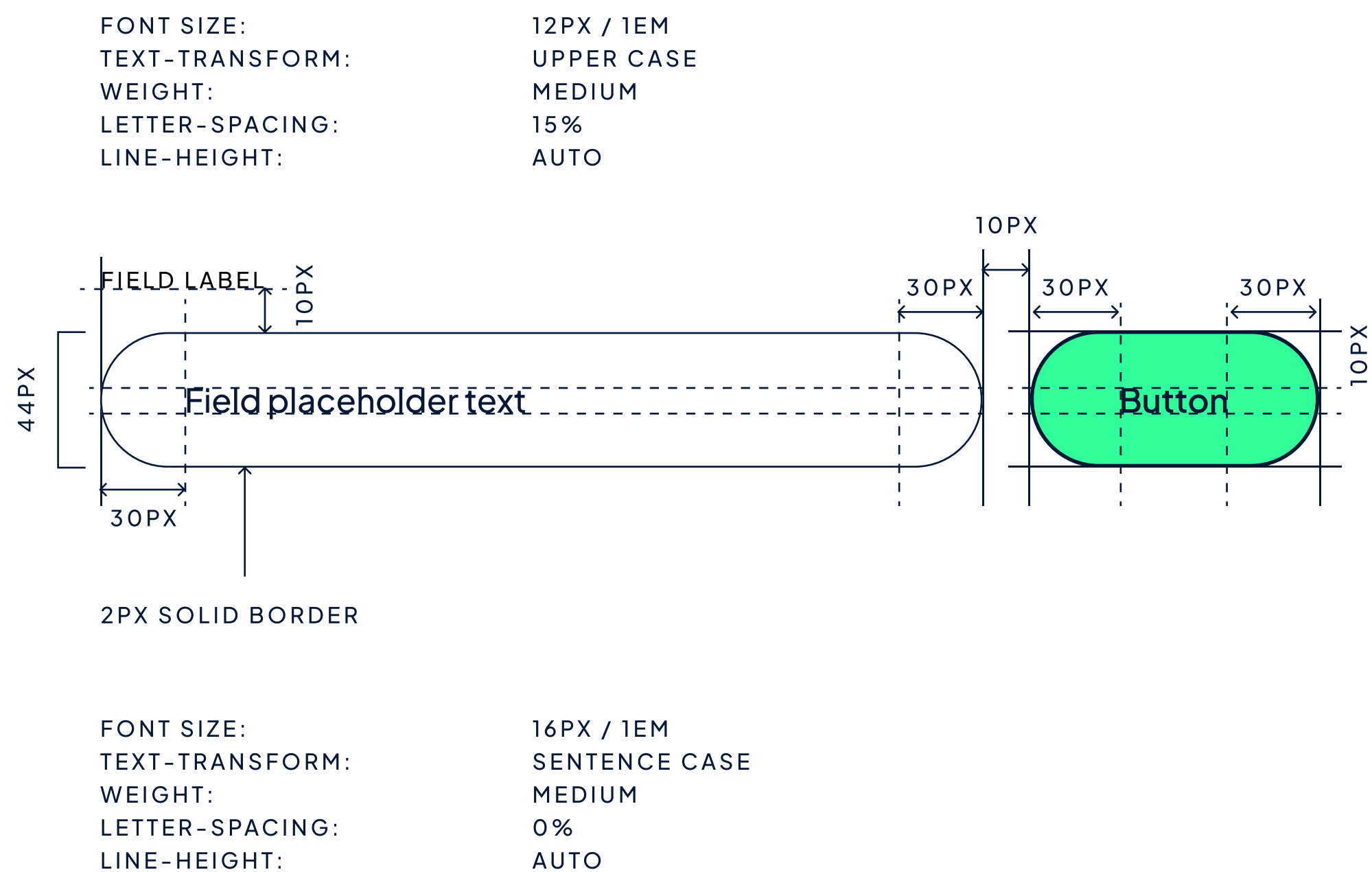

Layouts

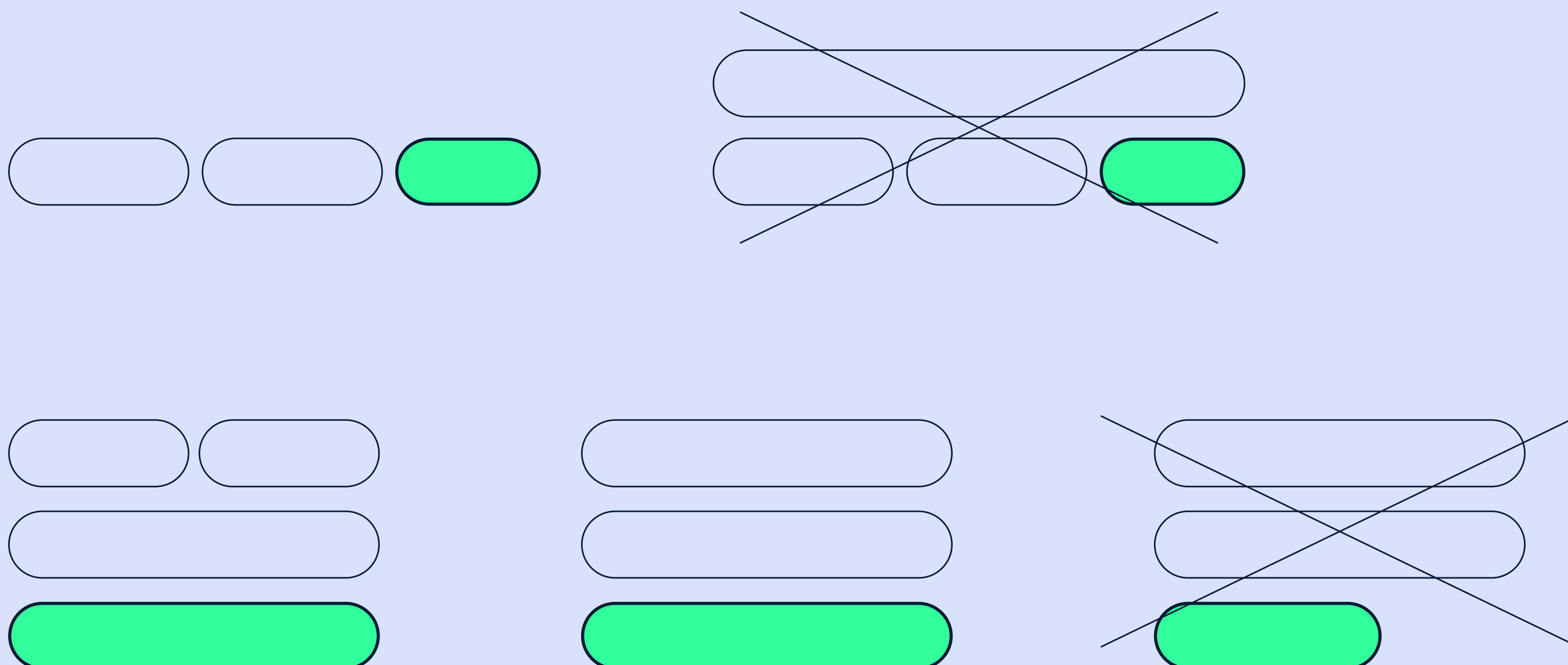

A form can be made up of multiple fields running horizontally in a single line, as well as single stacked fields that fill the entire width of the form container.

The sender's personal information is crucial as it's used to identify, contact and address them in future communication.

The user's preferences, selections and inputs are secondary.

The call-to-action should always be the final step in a form.

Inputs

Dropdowns

SELECT YOUR INDUSTRY



Asset and investment management

Banking

Financial consultant

Private banking

The 100% rounded corners should be applied to all field and text inputs in forms, however, the dropdown options may inherit the browser's default style values. This does not necessarily need to be customised, as long as the font is consistent.

Textboxes



The corners of textboxes should be rounded 75%.

Errors



THE PASSWORD YOU ENTERED IS INCORRECT, PLEASE TRY AGAIN.

COLOUR: #FF0000

When styling error messages and events, colours that are not part of primary brand palette need to be applied.

Social media

Post types

Blog article post



When a blog link is placed in the post copy, it will load a preview image and a meta data box underneath it. This entire section is hyperlinked, thus the link in the post copy can subsequently be removed.

Image post

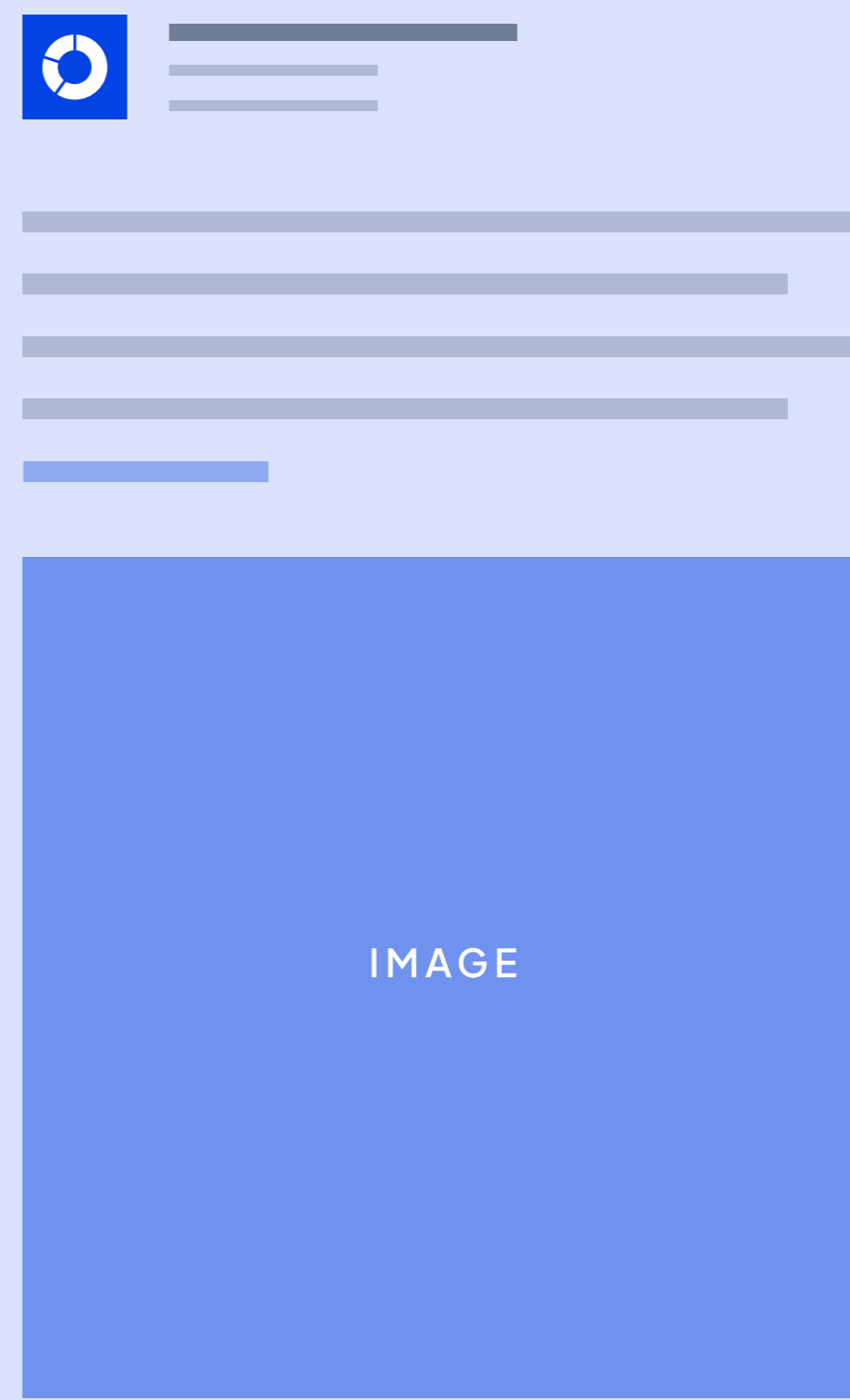

Uploading and posting an image directly to LinkedIn means you will need to include any links in the actual post copy, since an image can not be hyperlinked. We use shortened links in post copy to keep it clean.

Social media

Blog article post

LINKEDIN SOCIAL POST

A typical LinkedIn social posts consists of social post copy, a blog preview image, and meta data box which pulls the basic article information directly from the Kurtosys website when the link is pasted into the textbox.

AVATAR



SOCIAL POST COPY

Lorem ipsum dolor sit amet, consectetur adipiscing elit, sed do eiusmod tempor incididunt ut labore et dolore magna aliqua. Ut enim ad minim veniam, quis nostrud exercitation ullamco laboris nisi ut aliquip ex ea commodo consequat. Duis aute irure dolor in reprehenderit in voluptate velit esse cillum dolore eu fugiat nulla pariatur. Excepteur sint occaecat cupidatat non proident, sunt in culpa qui officia deserunt mollit anim id est laborum.

HASHTAGS

#InvestmentManagement #Sales #Marketing #ClientSuccess

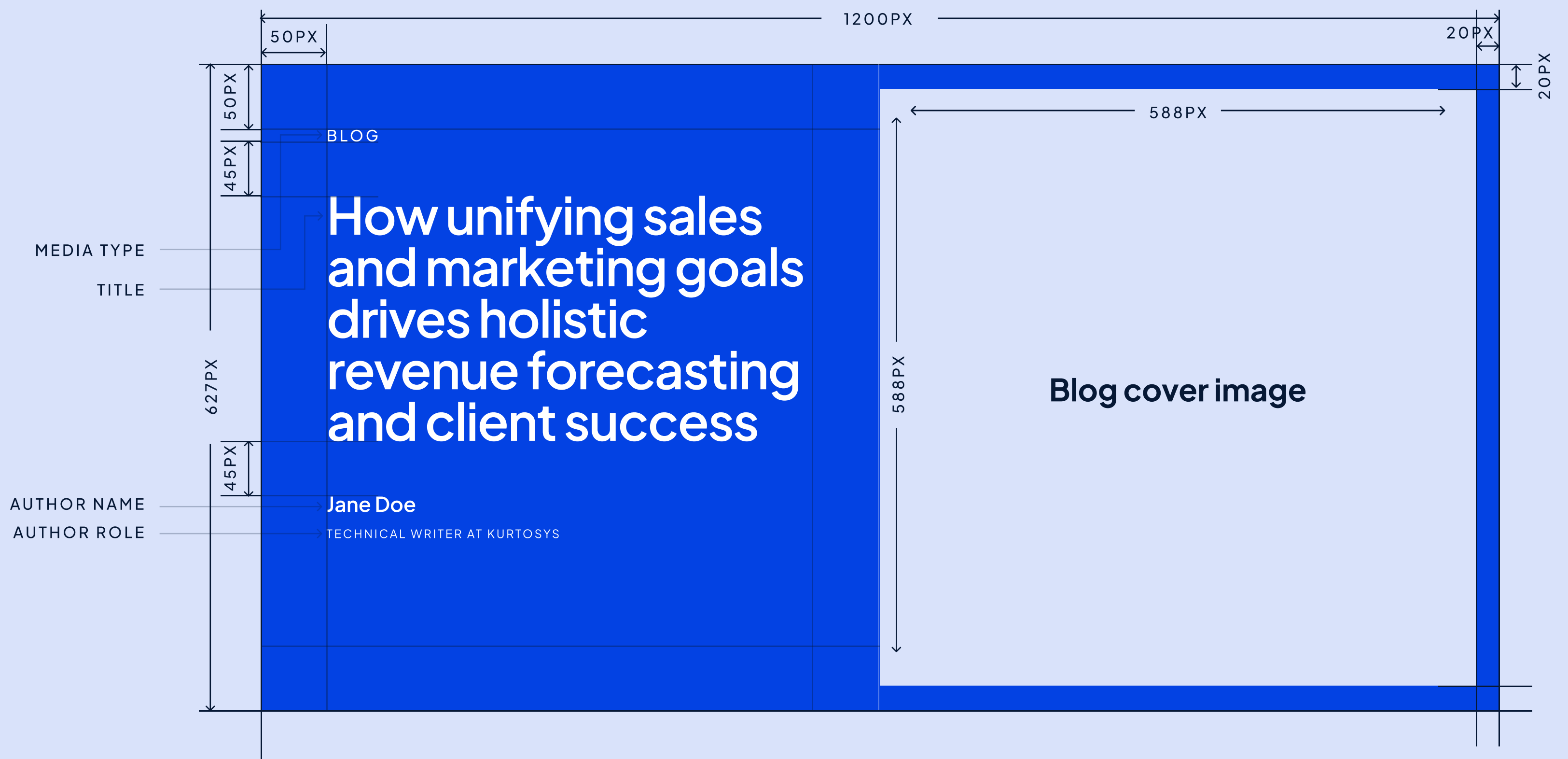

TITLE AS PUBLISHED

How unifying sales and marketing goals drive holistic revenue forecasting and client success

DOMAIN

WWW.KURTOSYS.COM

Email signature

Standard global email signature

Our standard global email signature consists of a personalised formal greeting to close off an email, followed by the name and surname, the role or designation, a link to our corporate website, a hyperlinked logo with a by-line, and hyperlinked social media icons.



White paper

White paper template

The white paper template is based in Adobe InDesign and employs various dynamic and interactive features that ensures a consistently branded layout that meets most typical requirements of an article.

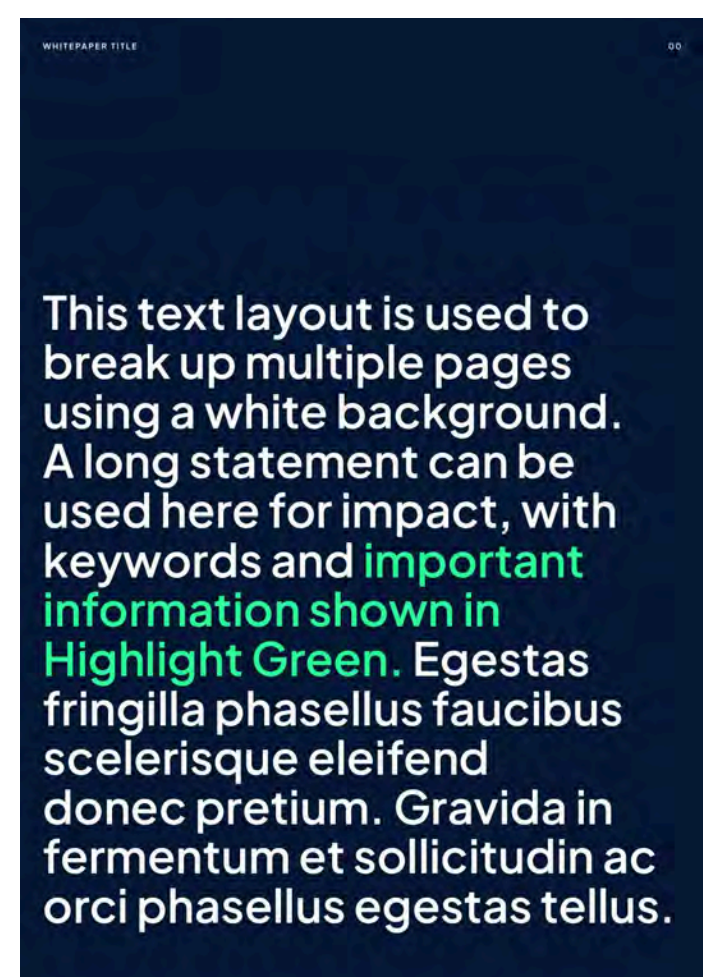
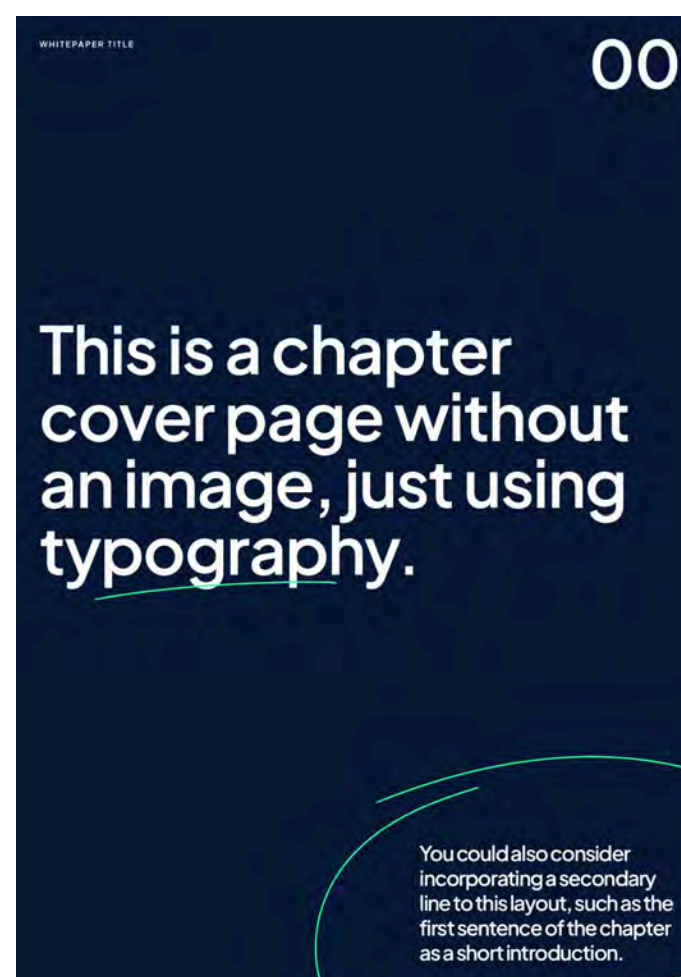
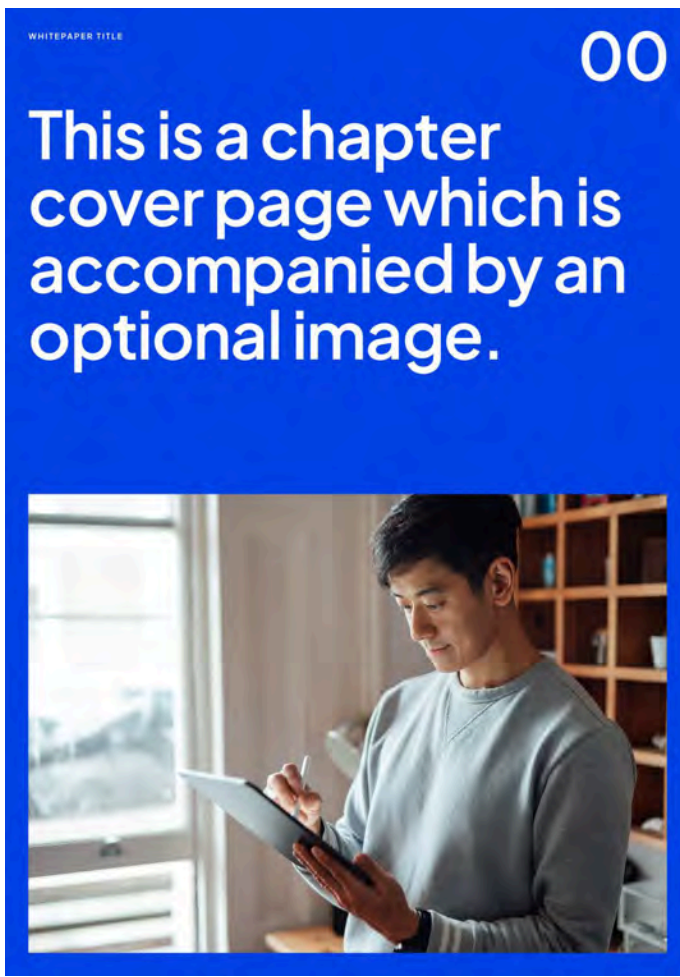
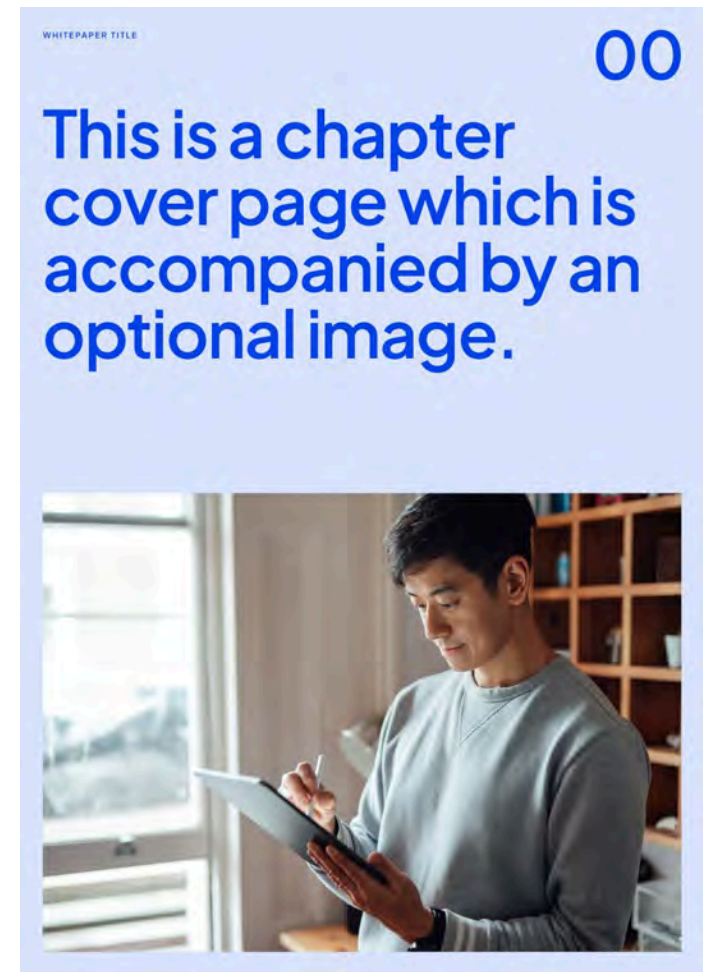
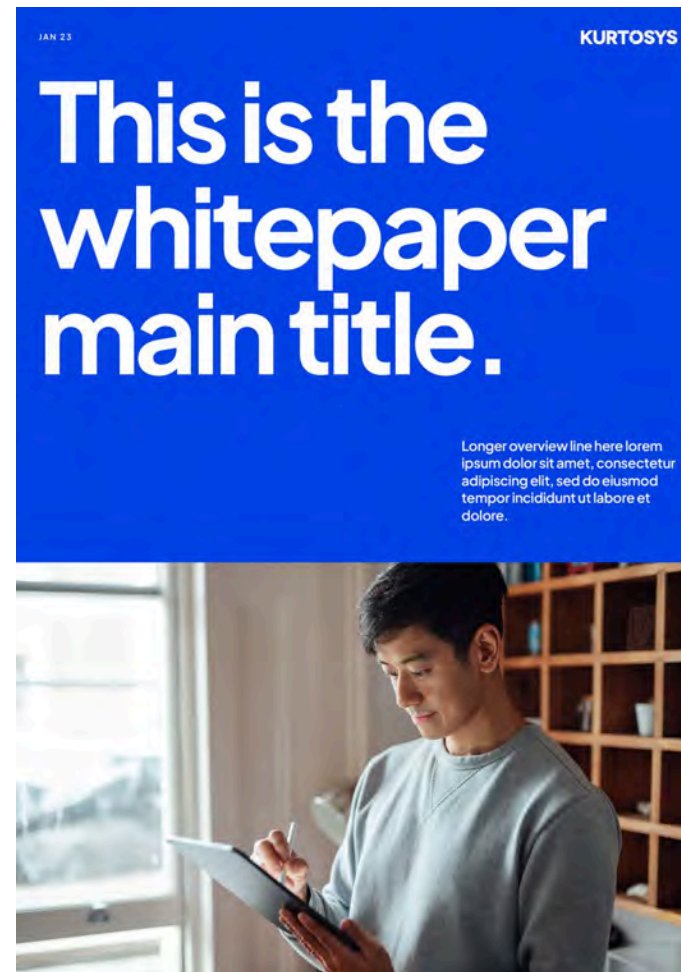

White paper

White paper template (cont.)

WHITEPAPER TITLE 00

This text layout is used to break up multiple pages using a white background. A long statement can be used here for impact. Egestas fringilla phasellus faucibus scelerisque eleifend donec pretium. Gravida in fermentum et sollicitudin ac orci phasellus egestas tellus.

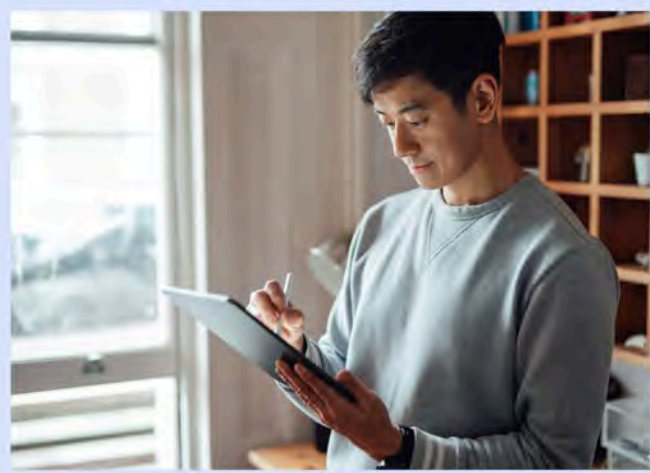

WHITEPAPER TITLE 00

This text layout is used to break up multiple pages using a white background. Anchor the text with a supporting image for the content.

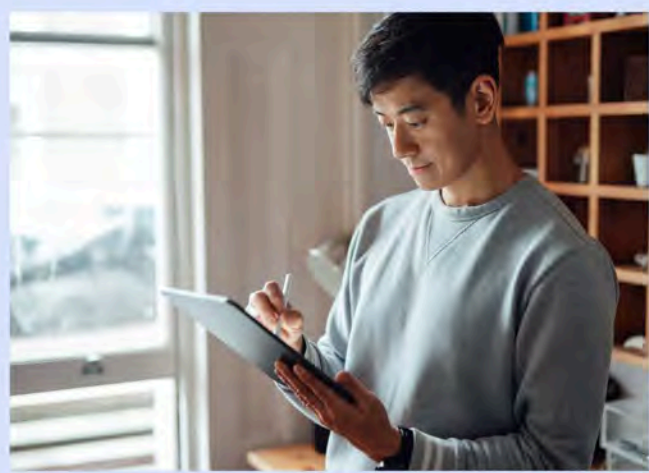

WHITEPAPER TITLE 00

This text layout is used to break up multiple pages using a white background. Anchor the text with a supporting image for the content.

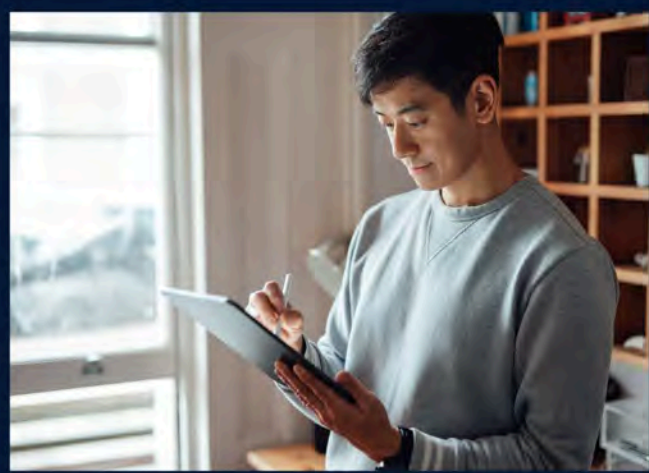

WHITEPAPER TITLE 00

This text layout is used to break up multiple pages using a white background. Anchor the text with a supporting image for the content.



WHITEPAPER TITLE 00



Sectionbreak title for single column text layouts



WHITEPAPER TITLE 00

Sectionbreak title for single column text layouts

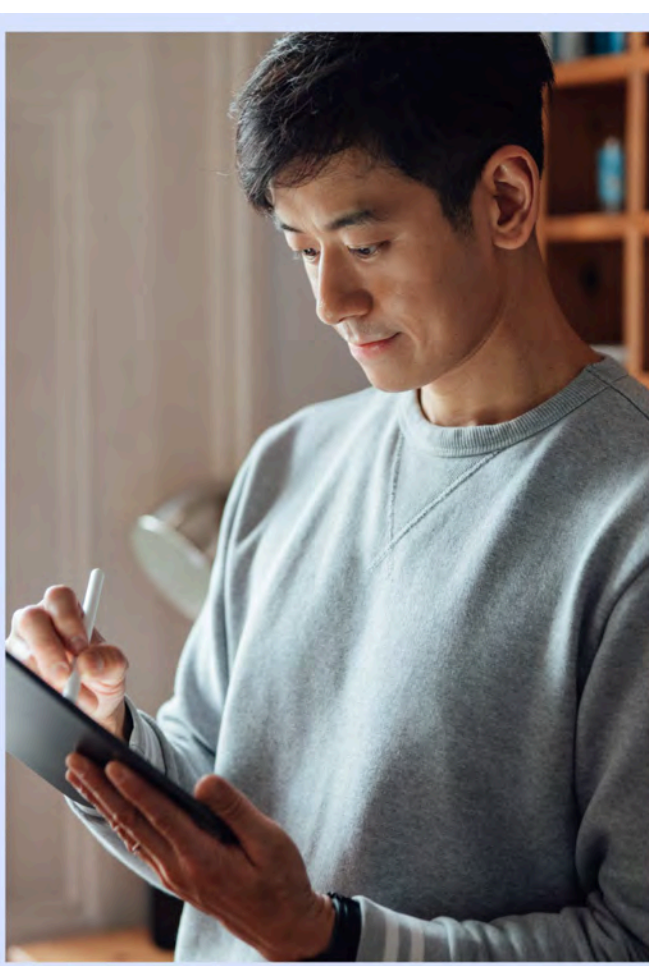

WHITEPAPER TITLE 00

Sectionbreak title for single column text layouts



WHITEPAPER TITLE 00

This text layout is used to break up multiple pages using a white background. Show keywords and important info in **Highlight Green.**

WHITEPAPER TITLE 00

Sectionbreak title for single column text layouts



WHITEPAPER TITLE 00

Sectionbreak title for single column text layouts

CONCLUSION

This is a large conclusion paragraph, gravida in fermentum et sollicitudin ac orci phasellus egestas tellus. A diam sollicitudin tempor id eu nisi. Ac feugiat sed lectus vestibulum mattis ullamcorper velit. Orci porta non pulvinar neque. Venenatis a condimentum vitae sapien.

Report authors:

ARTIST NAME
Placeholder text for author name and bio.

ARTIST NAME
Placeholder text for author name and bio.



KURTOSYS

PowerPoint

White paper template

The white paper template is based in Adobe InDesign and employs various dynamic and interactive features that ensures a consistently branded layout that meets most typical requirements of an article.

